



---

# TEMPERATURE CONTROL BOARD OPERATION MANUAL FOR AN, AS, AND AT SERIES AIR CONDITIONING UNITS



**Air Conditioners with Capacity of  
2,000 to 12,000 BTU/HR Nominal**

**115VAC & 208/230VAC Models**





---

## TABLE OF CONTENTS

1. Control Board Functionality and Overview .....	Page 3
2. Dip Switch Settings .....	Page 5
3. No-Timer Mode .....	Page 5
4. Cooling Set Point and Hysteresis.....	Page 6
5. Heating and Deadband Set Points.....	Page 7
6. Temperature Alarm Setpoint and LED Alarm Status .....	Page 7
7. High/low Pressure Operations/Monitoring and Pressure Alarm Light Status .....	Page 8
8. Temperature Display Mode.....	Page 9
9. Test Mode.....	Page 9
10. Alarm Output.....	Page 9
11. Fan Operation.....	Page 10
12. Initial Startup – Compressor Delay.....	Page 10
13. Electrical Wiring Diagrams.....	Page 11



---

**IMPORTANT NOTE: INSTALLER AND MAINTENANCE PERSONNEL SHALL REVIEW THIS MANUAL THOROUGHLY PRIOR TO INSTALLATION, STARTUP AND MAINTENANCE. FAILURE TO DO SO MAY RESULT IN IMPROPER OPERATION, UNIT DAMAGE, AND/OR PERSONAL/BODILY HARM.**

**ETHERNET CONTROLLED UNITS: IF A ETHERNET CONTROLLER IS USED PLEASE REFERENCE THE ETHERNET CONTROLLER ADDENDUM THE STANDARD TEMPERATURE CONTROL BOARD REFERENCED BELOW IS NOT INCLUDED IN ETHERNET MODELS**

### **Control Board Functionality and Overview (Non-Ethernet Models)**

The AN, AS, and AT series air conditioners include an electronic control board that provides monitoring of temperature and system operation with a simple and easy to use interface to allow the installer or maintenance technician to easily startup, operate, and diagnose/troubleshoot the unit. As shown in Figure 1, the control board is easily accessible from the upper interior cutout of the unit by removing the control board access panel. The key features of the control board are shown in Figure 2.

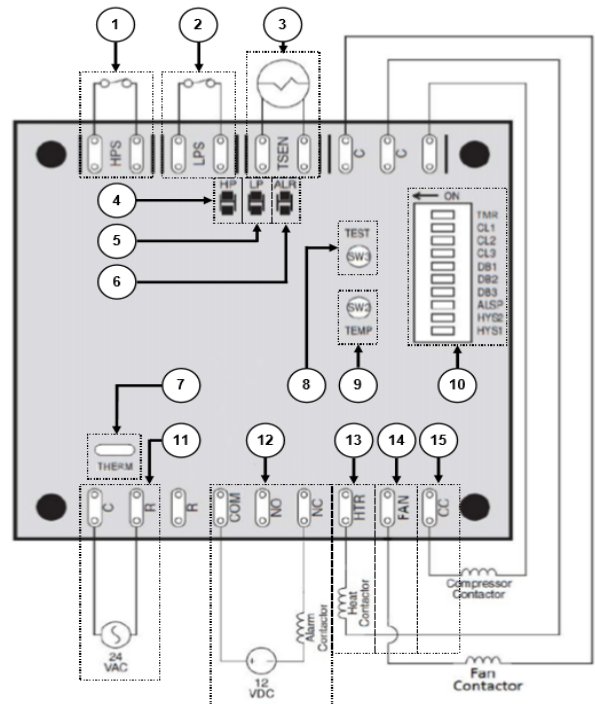

**Figure 1 – Control Board Access**

**Important Note:** On some previous models and/or special models the control board may be located elsewhere, such as via an access panel on the exterior of the unit.



ITEM NO.	DESCRIPTION
1	High pressure sensor input
2	Low pressure sensor input (Not Used)
3	Remote temperature sensor input
4	High pressure status (HP)
5	Low pressure status (LP)
6	Alarm (ALR)
7	On board temperature sensor
8	Test button (TEST)
9	Temperature Display (TEMP)
10	Setpoint DIP Switches
11	24VAC power terminals
12	Alarm (dry contacts NO/NC/COM*)
13	Heating Output
14	Fan output with Compressor Contactor
15	Compressor Contactor



\* Alarm Dry Contact is rated at 2A @ 12VDC, 1A @ 30VDC, 3A @ 125VAC, 2A @ 250VAC

**Figure 2 – Control Board Overview**

The controller provides control of cooling and heating (if the optional heater is included) with auto-change over between heating and cooling mode. The board includes adjustable DIP switches to allow user configuration of desired temperature alarming, as well as providing testing and diagnosis functions. The board monitors temperature utilizing an onboard temperature sensor and remote sensor (installed as standard option), and the board temperature display function provides for temperature sensor reading verification for diagnostic purposes. The remote temperature sensor is connected to board and located within the interior cabinet section near the interior fan. The board uses the remote temperature sensor for all operations. The onboard sensor is provided as a backup only with no effect on operation if the remote sensor is attached and functioning properly. The remote temperature sensor is installed within the interior fan section of the unit, however the remote temperature sensor includes a 6' long lead wire and may be relocated outside of the unit, if deemed necessary by the installer or service technician. Be careful **NOT** to install the sensor in an area that is not properly conditioned by the unit (e.g. rear of cabinet obstructed by equipment resulting in insufficient airflow and conditioning), as that may result in the unit freezing and/or resulting in equipment damage.

In addition to monitoring temperature for alarming purposes, the controller utilizes an input from the high pressure switch. The pressure sensor is provided to prevent permanent damage of the system due to system failure or lack of maintenance, as well as to provide a trouble alarm (LED status lights and alarm output). The pressure sensor monitoring and effect on sequence of operations is further discussed on Page 8



## Dip Switch Settings

The ten (10) DIP switches allow users to configure the controller for proper temperature and alarming. DIP switches are either ON (left position) or OFF (right position), as outlined below:

DIP Switch	DESCRIPTION	ON (LEFT)	OFF (RIGHT)	DEFAULT
TMR	5 MINUTE NO-TIMER MODE	NO-TIMER MODE ACTIVE	TIMER ACTIVE	Off
CL1	COOLING SETPOINT SWITCH 1	SEE TABLE 3 FOR COOLING SETPOINTS (DEFAULT COOLING SETPOINT – 81F)		Off
CL2	COOLING SETPOINT SWITCH 2			On
CL3	COOLING SETPOINT SWITCH 3			On
DB1	DEADBAND SWITCH 1	SEE TABLE 5 FOR DEADBAND (HEATING SETPOINT = COOLING SETPOINT MINUS DEADBAND) (DEFAULT DEADBAND 30F RESULTING IN DEFAULT HEATING SETPOINT OF 51F)		Off
DB2	DEADBAND SWITCH 2			On
DB3	DEADBAND SWITCH 3			On
ALSP	ALARM SETPOINT DIFFERENTIAL	4° DIFFERENTIAL	8° DIFFERENTIAL	Off
HYS1	COOLING HYSTERESIS SWITCH 1	SEE TABLE 4 FOR HYSTERESIS SETTINGS (DEFAULT IS 3 DEGREES BELOW COOLING SETPOINT)		On
HYS2	COOLING HYSTERESIS SWITCH 2			On

**Table 1 – Control Board DIP Switches**

**NOTE:** It should be anticipated that operating conditions change from location to location and the board may require installer/user adjustment to achieve the desired operating conditions. Installer and/or user to adjust board settings (cooling setpoints, deadband, hysteresis) based upon load conditions to minimize frequency of on-off cycles while maintaining max. and min. temperatures required for the cabinet/enclosure.

## NO-TIMER MODE

The NO-TIMER MODE allows an installer or maintenance technician to bypass all delays provided internal to the board (e.g. 5 min. anti-short cycling cooling delay). This switch may be used immediately after initial startup or cycling of power, or after the termination of a cooling or heating command. NO-TIMER MODE is active for 5 minutes after the NO-TIMER MODE is toggled from OFF to ON. During NO-TIMER MODE all timed delays will be ignored. However, to protect the compressor, a low or high pressure event will immediately terminate NO-TIMER MODE and the board will be locked out for cooling operation in order to protect the refrigeration circuit.

If the NO-TIMER MODE switch is left ON and power is cycled, the board will not permit a NO-TIMER MODE until after the switch is toggled OFF and back ON.



## COOLING SEPOINT AND OPERATION

Cooling setpoint is based upon CL1/CL2/CL3 positions as shown below in Table 2. The board will energize cooling operation immediately upon the temperature sensor reading a temperature 1°F above the cooling setpoint, as long as the board is not in a cooling delay (5 minutes). The cooling operation will terminate when the temperature sensor reads a temperature equal to the setpoint less the hysteresis, with the hysteresis settings shown below in Table 3.

The hysteresis is the differential below the cooling setpoint when the unit will stop cooling operations. The Hysteresis is set per Table 3. As an example, if the cooling setpoint is 81° and the Hysteresis is set to 3°, the cooling operation will begin at 82° (Cooling Setpoint + 1°) and will terminate cooling operations at 78° (81° - 3°).

The cooling delay is used to prevent short cycling, which may cause premature unit failure. The 5 minute cooling delay is active upon initial startup, power cycling, and following the termination of the previous cooling operation. This delay may be temporarily bypassed, as discussed above with NO-TIMER MODE.

COOLING SETPOINT			
CL1	CL2	CL3	SETPOINT
ON	ON	ON	93
ON	ON	OFF	90
ON	OFF	ON	87
ON	OFF	OFF	84
OFF	ON	ON	81
OFF	ON	OFF	78
OFF	OFF	ON	75
OFF	OFF	OFF	72

**Table 2 – Cooling Setpoint Settings**

**NOTE:** Initial cooling operation in no or low load conditions may result in delayed cooling. This delay while the compressor is operating may be 3-6 minutes and the condenser fan may not be operating during this time due to the low ambient control/head pressure switch.

COOLING HYSTERESIS		
HYS1	HYS2	HYSTERESIS
ON	ON	3
ON	OFF	6
OFF	ON	9
OFF	OFF	12

**Table 3 – Offset From Cooling Setpoint Settings**



## **HEATING SETPOINT AND OPERATION**

Heating setpoint is set based upon the deadband DIP switch settings. Heating setpoint is equal to the cooling setpoint minus the deadband. The deadband DIP switch settings are identified below in Table 4. The board will energize heating operation immediately upon the temperature sensor reading a temperature 1°F below the heating setpoint (Cooling Setpoint minus Deadband), as long as the board is not in a 2 minute heating delay during initial startup or following the previous heating operation. Heating operation will stop when the temperature is 2°F above the heating setpoint. A 2 minute heating delay is active upon initial startup, power cycling, and following the termination of the previous heating operation. This delay may be temporarily bypassed, as discussed above with NO-TIMER MODE.

<b>DEADBAND SETPOINT</b>			
DB1	DB2	DB3	DEADBAND
ON	ON	ON	6
ON	ON	OFF	12
ON	OFF	ON	18
ON	OFF	OFF	24
OFF	ON	ON	30
OFF	ON	OFF	36
OFF	OFF	ON	42
OFF	OFF	OFF	48

**Table 4 – Deadband Setpoint Settings**

## **TEMPERATURE ALARM SETPOINT AND ALARM LED LIGHT STATUS**

The temperature alarm setpoint operates for both cooling and heating, and is based upon the alarm differential from setpoint, with DIP switch settings below in Table 5 provided for alarm differential. For cooling, this alarm setpoint is the cooling setpoint plus the alarm differential. For heating the alarm setpoint is the heating setpoint less the alarm differential. A ten (10) minute delay is used to prevent nuisance temperature alarms. If the board measures a temperature above/below the temperature alarm setpoint for 10 minutes, the board will activate the alarm output as further discussed below.

<b>ALARM DIFFERENTIAL</b>	
ALSP	Alarm Differential from Cooling/Heating Setpoint
ON	4°
OFF	8°

**Table 5 – Alarm Differential from Cooling**



As with the alarm output, the TEMP LED will be solid red during an active temperature alarm. The board will continue to operate with all functions for cooling and/or heating during a temperature alarm. If the temperature alarm clears, the alarm output will be deactivated and the TEMP LED will flash for a period of 100 hours. A subsequent temperature alarm, if any, will repeat the process with the same sequence. The active temperature alarm LED and alarm output may be cleared by cycling power to the unit.

If a heater is not installed in the unit, it is recommended that the deadband be set to 48 to help prevent alarming for low temperature. Alternative to or in addition to, the installer may install a relay to the heater output terminal on the control board to eliminate the low temperature alarm output.

## **HIGH/LOW PRESSURE OPERATIONS/MONITORING AND PRESSURE ALARM LIGHT STATUS**

High pressure sensors are standard on all AN, AS, and AT series air conditioners. Low pressure sensors are optional and if not included, a jumper will be placed on the board across the two low pressure input terminals to bypass the monitoring of low pressure.

The high pressure and low pressure switches are continuously monitored during an active cooling operation. If either pressure switch opens identifying either low or high pressure, the unit will immediately shut down for a soft lockout and the respective pressure LED (HP or LP) will flash. The unit will not start cooling operation if the high pressure switch is open during initial start or following a soft lockout. If the low pressure switch is open during initial start or following a soft lockout the unit will begin cooling operations for a two (2) minute low pressure bypass period, and if the low pressure switch remains open, the unit will terminate cooling operation.

A five (5) minute soft lockout period follows a termination of cooling operation due to a pressure switch opening. During a soft lockout the board will not energize cooling operation. Upon the termination of the soft lockout period the board will attempt to restart the cooling operation and repeat the process. If the board experiences three (3) pressure soft lockouts within a 90 minute period the board will provide an alarm output and enter a hard lockout. A hard lockout will not permit cooling operation and a may only be cleared by cycling power to the unit.

Important Note: The pressure switches are NOT monitored during the 5 minute cooling delay. The NO-TIMER MODE may be used to bypass the 5 minute delay to quickly determine if a switch is open. However be advised that the board will immediately process a hard lockout with a single pressure switch failure while in NO-TIMER MODE. This diagnostic process allows quick verification of pressure switch status while protecting the compressor against repeated starts.

The LED lights for high pressure (HP) and low pressure (LP) provide a visual indication of status. A solid light indicates an active hard lockout of the respective switch whereas a flashing light reflects a soft lockout had occurred within the previous 100 hours. Cycling power to the unit will reset the LED lights.







---

## **FAN OPERATION**

The internal fan is energized only when the control board provides a command for cooling or heating. If the user prefers continuous fan operation, the line voltage fan blue wire from the fan to the fan relay may be relocated to the continuous power side of the compressor contactor. This continuous interior fan adjustment is noted on the wiring diagram. Disconnect power to the unit prior to making this wiring change.

## **NOTE ABOUT INITIAL UNIT STARTUP – COMPRESSOR DELAY**

Initial cooling operation in no or low load conditions may result in delayed cooling. This delay while the compressor is operating may be 3-6 minutes and the condenser fan may not be operating during this time due to the low ambient control/head pressure switch.



## 7. ELECTRICAL WIRING DIAGRAM

The following table can be used to identify components on the electrical schematic.

Main Electrical Components		Control Board	
CR1	Contactor and Distribution Block	HPS	High Pressure Control
R1	Relay 1 (Heater)	LPS	Low Pressure Control
R2	Relay 2 (Interior Fan)	TESN	Temperature Sensor
T1	24VAC Transformer	C	Common
TS-1	Thermal Protection Disc 1	R	24VAC
TS-2	Thermal Protection Disc 2	COM	Common
Hard Start Relay		NO	Normally Open
High Pressure Switch		NC	Normally Closed
Low Pressure Switch		HTR	Heating Component
Low Ambient Control		FAN	Cooling Component
		CC	Compressor Contactor

Table 6 – Electrical Schematic Key

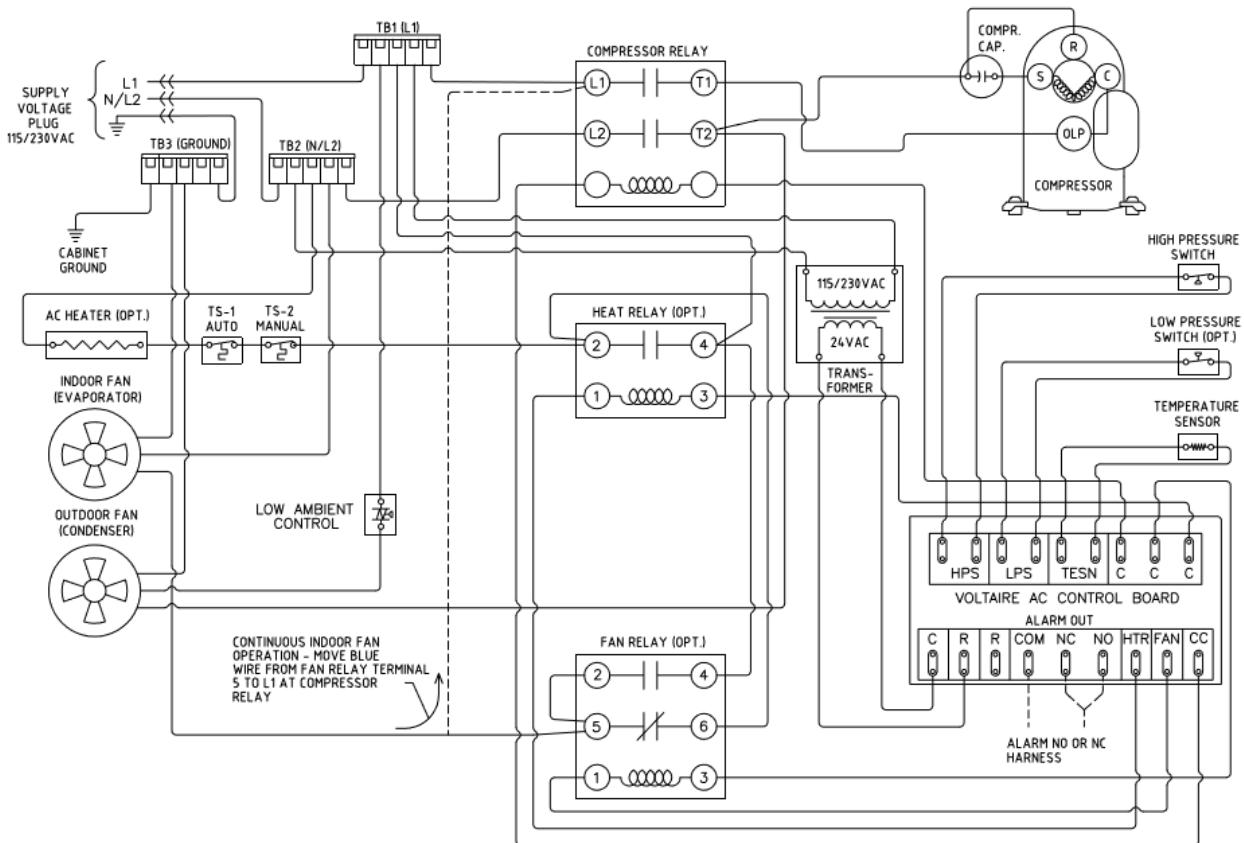

b

Figure 3 – AN02 / AS02 Electrical Wiring Diagram (No Hard Start)

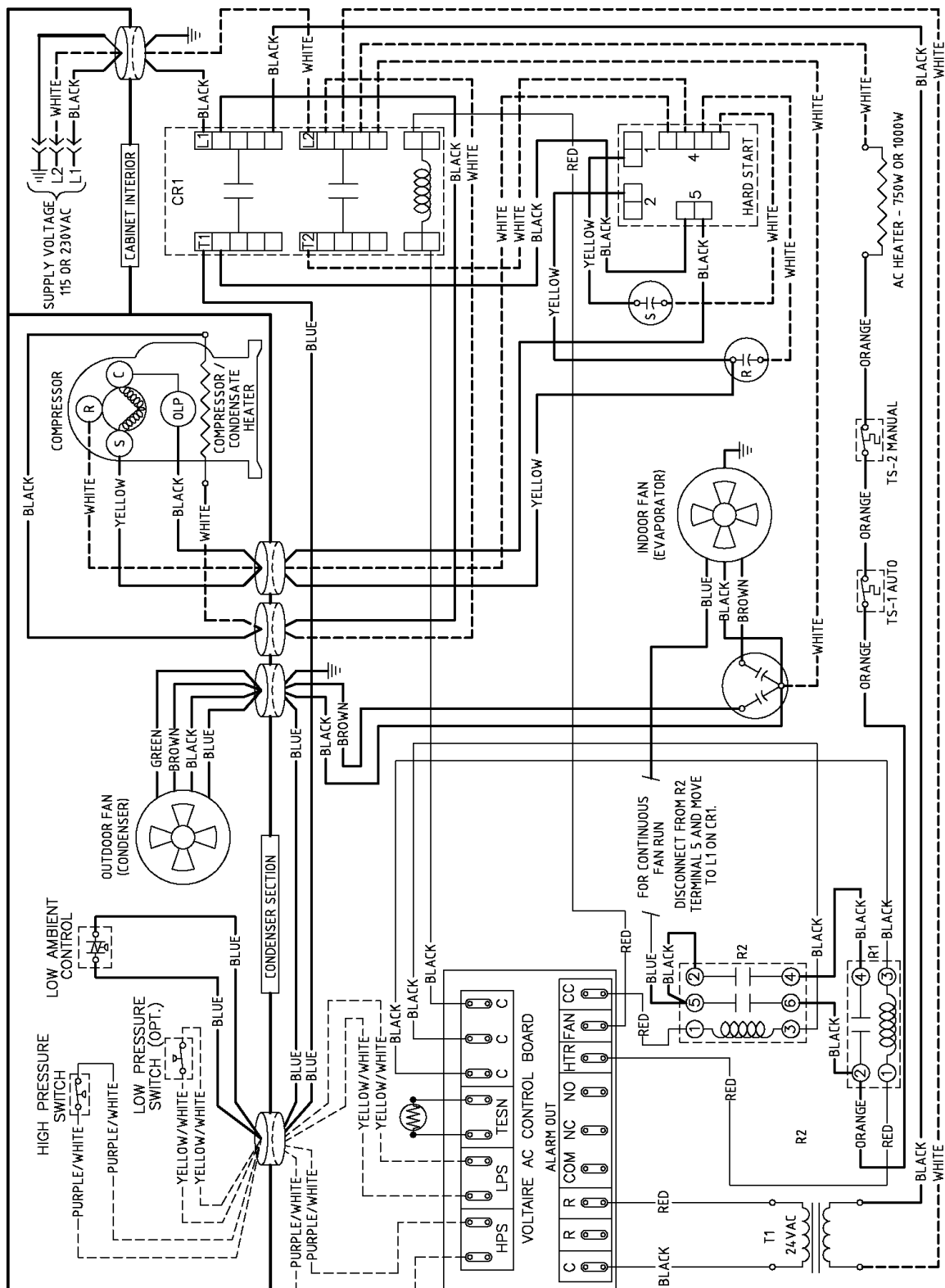

Figure 4 – AT04-12 / AN04-08 / AS04-12 Electrical Wiring Diagram with Hard Start

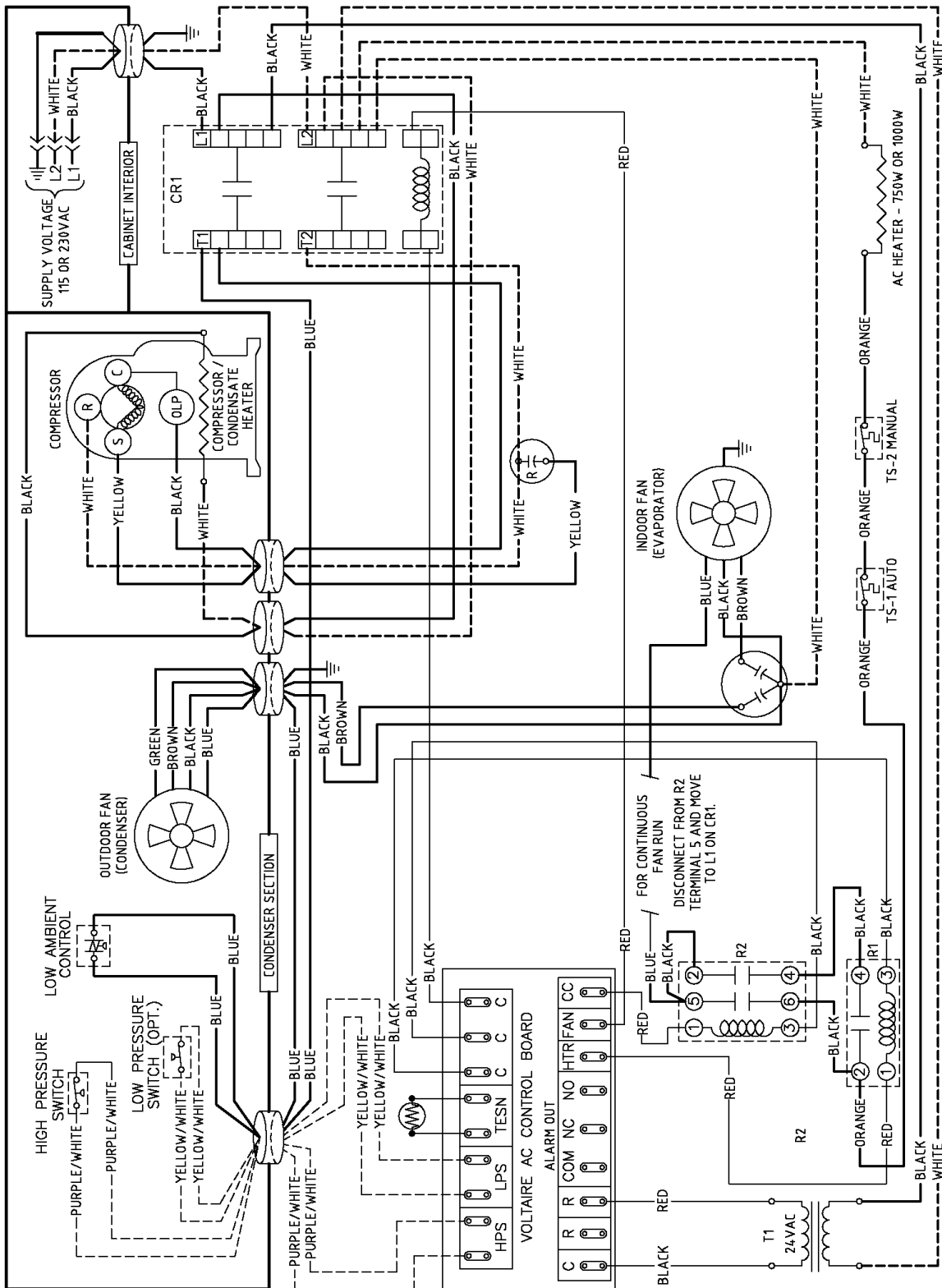

Figure 5 – AT04-12 / AN04-08 / AS04-12 Electrical Wiring Diagram without Hard Start